

We build a better future



■ Photo may include optional equipment

HYUNDAI DIESEL FORKLIFT TRUCKS - Environmental-Friendly

110D/130D/140D/160D-7E

 **HYUNDAI**
HEAVY INDUSTRIES EUROPE



Full Equipment



Cruise control



Switch panel



Air conditioning & heater



Rear view camera (Option)



Monitor (Option)



Start-up restriction (Option)

NEW criterion of Big Forklift Truck

Hyundai introduces a new line of 7E-series diesel forklift trucks. Excellent power and performance make your business more profitable.



■ Photo may include optional equipment

The new master on your job-site!

Smooth running, efficient and ergonomically designed, 110D/130D/140D/160D-7E series are made to meet your needs.



Powerful Engine

Cummins QSB6.7 Engine

The six cylinders turbo-charged engine is built for power, reliability and economy. This engine meets EPA Tier 3 and EU stage IIIA emission regulation.



Engine control mode

According to the application, the operator can select the preferable engine mode with a single switch.

STANDARD Mode : Fuel efficient mode for light applications

POWER Mode : Full power mode for heavy-duty applications



Adjustable engine idling RPM

With engine running, idling rpm can be adjusted by units of 25rpm, this preset is saved automatically.

119 kW / 2,200 rpm
731.6 N.m / 1,400 rpm

Full-automatic transmission

The Full-automatic transmission offers easy and convenient handling with soft, smooth shifting. The operator can select two types of automatic modes. (1st↔3rd, 2nd↔3rd)



Cruise control

Maintain automatically a desired engine speed with no accelerator pedal input in order to reduce fuel consumption and operator fatigue.



Transmission control switch



Excellent night work

- Various positions of work lamps provide the operator with better visibility, higher level of comfort and safer operation.
- Front working lamps: 2 pc. on fender, 2pc. on mast(2)
- Rear working lamps: 2 pc. on cab



High Power Low Noise



■ Photo may include optional equipment

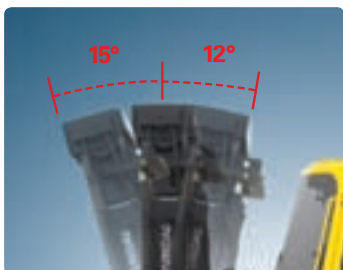

Increased mast tilting angle
Utilizing the mast tilting angle of 15 degrees forward and 12 degrees backward, the operator can perform (un)loading jobs safe and rapidly.

Faster travel speed & better grade-ability

The powerful engine provides great acceleration, high grade-ability and fast travel speed on tough terrain or slopes.



Grade-ability (Loaded)

110D-7E : 36.9 % 140D-7E : 30.0 %
130D-7E : 33.2% 160D-7E : 27.5 %

Travel speed (Unloaded)

110D-7E : 35.0 km/h
130D-7E : 34.8 km/h
140D-7E : 33.8 km/h
160D-7E : 33.6 km/h

Comfortable operation!

A design based on human engineering relieves fatigue and increases operator's efficiency.

Operator friendly gauges and water-resistant monitor panel



Easily adjustable suspension seat

An attractive and adjustable seat, based on human engineering design, provides great comfort, safety and durability. (Head rest - option)

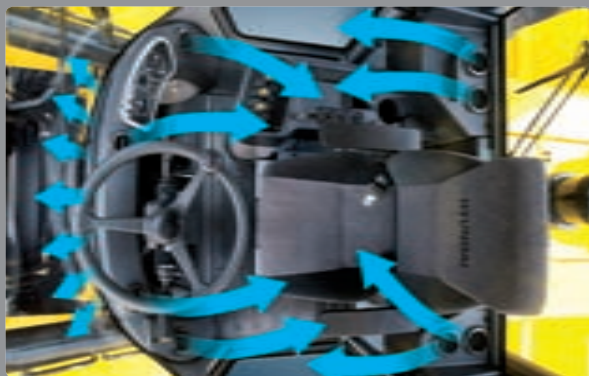

High-capacity air conditioner & heater

An integrated air conditioner and heater saves space inside the cabin. With its high capacity, the operator is, both in summer and winter, able to create a pleasant operating environment.



Start-up restriction - ESL / Rear view camera monitor (option)

When activated through the menu of the monitor, the engine can only be started after entering the right password. This ESL-function will prohibit your forklift truck from theft, with an interruption of the fuel injection-system of the engine. The rear view camera offers convenience and safety for the operator and the environment of the forklift truck. With 4 possible camera channels, all blind spots are eliminated.



Concentrated switch panel



MP3 / CD Player with remote control



Hands free socket





■ Photo may include optional equipment



Quick response of hydraulic levers

Only minimal operator's effort is required for precise, safe and productive control. (3-Levers : standard // 4 or 5-Levers : option)



Ergonomical positioned pedals

Based on human engineering, the accelerator, brake and inching pedals are optimally positioned for operator's convenience.

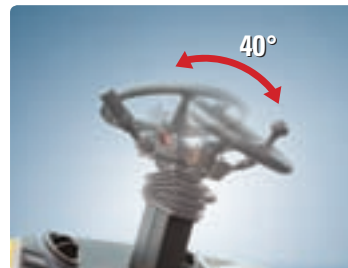

Adjustable steering column

Steering column can be adjusted depending on the operator's preferences to create a comfortable operating environment.



Safety through high durability!

Safety and durability are priorities in design of our equipment.



Hydraulic driven cooling system

With sensors for intake air temperature, transmission oil temperature, coolant temperature and hydraulic temperature, the speed of the hydraulic driven cooling fan is minimized to reduce fuel consumption and noise level and to increase overall performance.



OPSS (Operator Presence Sensing System)

Mast tilting, lifting and lowering operation is not possible when the operator is not seated in the normal position.



Durable drive axle

The drive axle with hypoid type planetary reduction smoothly delivers the desired torque to the drive wheels.

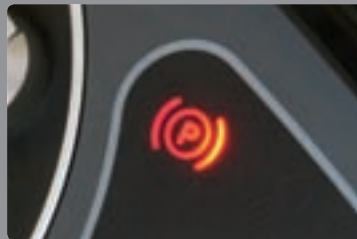

Auto parking

The parking brake is engaged automatically when the transmission is in neutral position and the operator leaves the seat.



Wet disc brake system

Wet disc brakes improve the brake performance and make your service intervals longer. Enclosed brakes are protected against dust and water.



Protector for hub bolts

By applying protector for preventing bolts breakage durability has been improved. (Same size of front and rear wheels)



Cylinder guard

This guard helps to prevent possible damage on the cylinder when



Grease fittings

Grease fittings are installed for easy access to steering axle center pin when doing service checks.



■ Photo may include optional equipment



Durable mast & carriage side rollers

Side rollers with great durability for mast and carriage are used.



Reliable fork carriage

The fork carriage of high tensile structural steel has an excellent durability and is very reliable. Working in narrow spaces is easier with a smaller width of the fork carriage than the overall width of the vehicle.



Large footboard & handle

Wide "open" step offers convenience and safety when entering and exiting your truck.

Centralized design for easy service!

An ideal arrangement of components ensures easy access and convenience for maintenance.



Large engine hood

Highly accessible engine compartment assures fast and efficient maintenance.



Easy change of air cleaner

This air filter is readily accessible for cleaning or replacement.



Cabin tilting for servicing purposes

A hydraulic cylinder tilts the operator cabin to left side about 65 degrees for easy access to the main components. Cabin tilting simplifies servicing of all power train components.



Cabin air fresh filter

To exclude dust and to reduce noise levels there's a low overpressure maintained inside the cabin.



Compact fuse box for easy inspection



Fuel prefilter with water-separator

Equipped with a manual priming pump, the fuel prefilter with water-separator will keep water and contaminations out of the fuel system.



Electrically monitored air filter

Air cleaner sensor alerts the operator of a clogged air filter and allows replacement before damage.

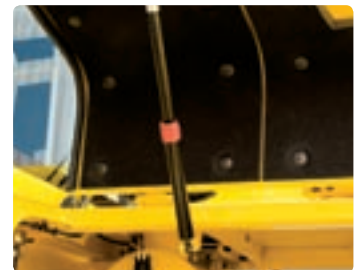

Automatic locking gas spring

Engine compartment hood is safely kept open by a self locking gas spring.



■ Photo may include optional equipment



Master switch

A master switch disconnects the battery power to protect the electrical system from electrical drainage.



Large tool box



Pressure gauge port



Easy engine oil check

Mast specifications

Mast Type		Maximum Fork Height (mm)	Overall Height Lowered (mm)	Tilt Angle (degrees)	Load Capacity 600 mm LC (kg)		Truck Weight Unloaded (kg)	
					110D/130D-7E		110D-7E	130D-7E
2-Stage Limited Free Lift	V300	3,005	3,000	15 / 12	11,000	13,000	15,722	16,427
	*V330	3,305	3,150	15 / 12	11,000	13,000	15,797	16,503
	V350	3,505	3,250	15 / 12	11,000	13,000	15,847	16,552
	V400	4,005	3,550	15 / 12	11,000	13,000	16,100	16,805
	V450	4,505	3,800	15 / 12	11,000	12,600	16,225	16,930
	V500	5,005	4,100	15 / 12	11,000	12,200	16,374	17,079
	V550	5,505	4,350	15 / 12	11,000	11,800	16,605	17,310
	V600	6,005	4,650	15 / 12	10,600	11,400	16,757	17,462
	V650	6,505	4,900	15 / 12	10,300	11,100	16,890	17,595
3-Stage Full Free Lift	TF440	4,405	2,950	10 / 10	11,000	12,300	16,761	17,467
	TF470	4,705	3,050	10 / 10	11,000	12,100	16,832	17,538
	TF500	5,005	3,150	10 / 10	11,000	11,800	16,903	17,609
	TF550	5,505	3,317	10 / 10	10,600	11,500	17,070	17,776
	TF600	6,005	3,484	10 / 10	10,300	11,100	17,188	17,894
	TF650	6,505	3,651	10 / 10	9,600	10,800	17,402	18,108
	TF700	7,005	3,818	10 / 10	8,700	10,500	17,521	18,227

Mast Type		Maximum Fork Height (mm)	Overall Height Lowered (mm)	Tilt Angle (degrees)	Load Capacity 600 mm LC (kg)		Truck Weight Unloaded (kg)	
					140D/160D-7E		140D-7E	160D-7E
2-Stage Limited Free Lift	V295	2,950	2,950	15 / 12	14,000	16,000	18,120	18,977
	V300	3,010	3,250	15 / 12	14,000	16,000	18,284	19,141
	*V330	3,310	3,400	15 / 12	14,000	16,000	18,378	19,235
	V350	3,510	3,500	15 / 12	14,000	16,000	18,423	19,280
	V400	4,010	3,750	15 / 12	14,000	16,000	18,710	19,567
	V450	4,510	4,000	15 / 12	14,000	15,900	18,865	19,722
	V500	5,010	4,300	15 / 12	14,000	15,900	19,047	19,904
	V550	5,510	4,550	15 / 12	13,600	15,200	19,316	20,173
	V600	6,010	4,850	15 / 12	13,200	14,600	19,498	20,355
	V650	6,510	5,125	15 / 12	12,800	14,100	19,664	20,521
3-Stage Full Free Lift	TF395	3,964	2,950	10 / 10	14,000	15,600	19,385	20,254
	TF450	4,504	2,950	10 / 10	13,900	15,300	19,546	20,415
	TF500	5,004	3,297	10 / 10	13,500	14,900	19,721	20,590
	TF550	5,504	3,464	10 / 10	12,900	14,500	19,904	20,773
	TF600	6,004	3,631	10 / 10	12,600	14,100	20,059	20,923
	TF650	6,504	3,798	10 / 10	12,200	13,700	20,338	21,207
TF700	7,004	3,965	10 / 10	11,900	13,400	20,481	21,350	

Load capacity

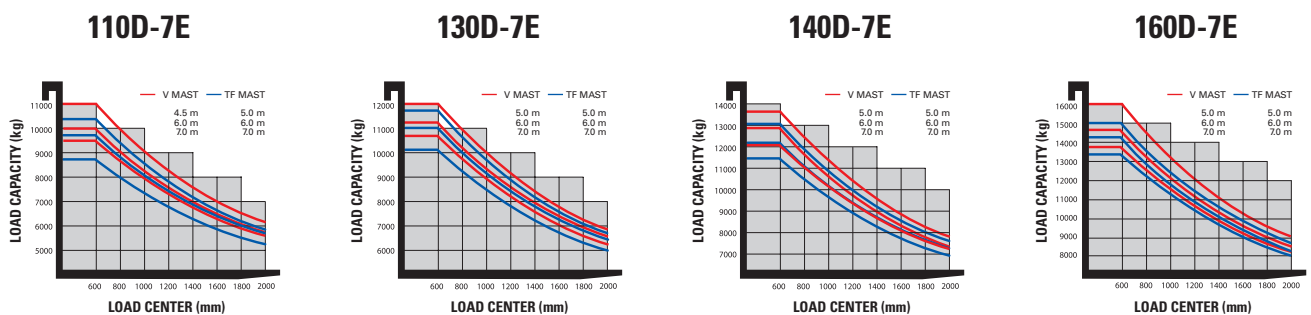

Dimensions

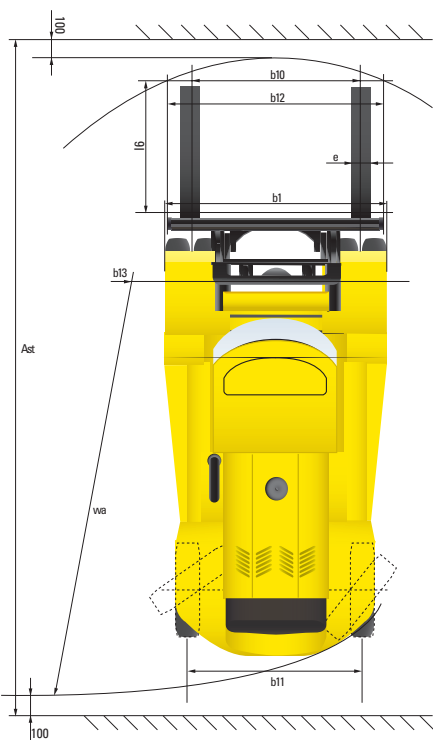
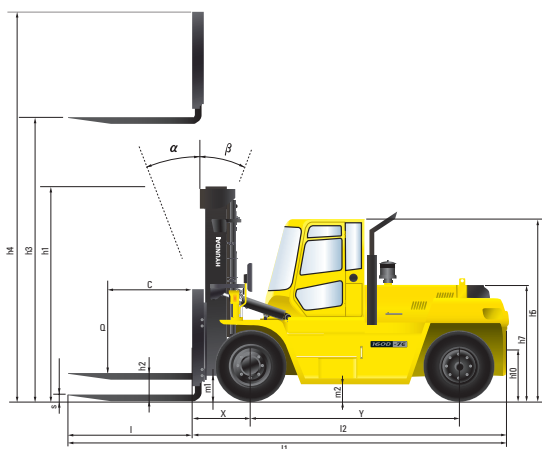

Specifications

Identification						
1.1	Manufacturer		Hyundai	Hyundai	Hyundai	Hyundai
1.2	Type		110D-7E	130D-7E	140D-7E	160D-7E
1.3	Drive: electric (battery or mains), diesel, petrol, fuel gas, manual		DIESEL	DIESEL	DIESEL	DIESEL
1.4	Type of operation: hand, pedestrian, standing, seated, order-picker		seated	seated	seated	seated
1.5	Load capacity (standard)	Q (t)	11.0	13.0	14.0	16.0
1.6	Load center distance	c (mm)	600	600	600	600
1.8	Load distance, center of drive axle to forks	x (mm)	755	760	830	835
1.9	Wheelbase	y (mm)	2,900	2,900	3,300	3,300
Weights						
2.1	Service weight	kg	15,797	16,503	18,378	19,235
2.2	Axle loading, loaded front/rear	kg	23,844 / 2,625	26,702 / 2,802	29,350 / 3,028	32,199 / 3,036
2.3	Axle loading, unloaded front/rear	kg	7,704 / 7,765	7,605 / 8,898	9,283 / 9,095	9,241 / 9,994
Wheels, chassis						
3.1	Tires: solid rubber, superelastic, pneumatic, polyurethane		Pneumatic	Pneumatic	Pneumatic	Pneumatic
3.2	Tires size, front		10.0 - 20	10.0 - 20	12.0 - 20	12.0 - 20
3.3	Tires size, rear		10.0 - 20	10.0 - 20	12.0 - 20	12.0 - 20
3.5	Wheels, number front / rear (X= driven wheels)		4 x / 2	4 x / 2	4 x / 2	4 x / 2
3.6	Track width, front	b10 (mm)	1,842	1,842	1,842	1,842
3.7	Track width, rear	b11 (mm)	1,910	1,910	1,955	1,955
Basic dimensions						
4.1	Mast/fork carriage tilt forward/backward	degrees	15 / 12	15 / 12	15 / 12	15 / 12
4.2	Lowered mast height (standard)	h1 (mm)	3,000	3,000	3,250	3,250
4.3	Free lift	h2 (mm)	0	0	0	0
4.4	Lift height (standard)	h3 (mm)	3,005	3,005	3,010	3,010
4.5	Extended mast height (standard)	h4 (mm)	4,465	4,465	4,710	4,710
4.7	Overhead load guard (cab) height	h5 (mm)	2,900	2,900	2,935	2,935
4.8	Seat height / standing height	h7 (mm)	1,723	1,723	1,749	1,749
4.12	Coupling height	h10 (mm)	600	600	600	600
4.19	Overall length	l1 (mm)	5,690	5,695	6,250	6,255
4.20	Length to face of forks	l2 (mm)	4,340	4,345	4,900	4,905
4.21	Overall width	b1 (mm)	2,450	2,450	2,497	2,497
4.22	Fork dimensions LxWxT	l / e / s (mm)	1,350 x 200 x 75	1,350 x 200 x 85	1,350 x 200 x 85	1,350 x 200 x 90
4.23	Fork carriage type		Shaft type	Shaft type	Shaft type	Shaft type
4.24	Fork carriage width	b12 (mm)	2,357	2,357	2,497	2,497
4.31	Ground clearance, loaded, under mast	m1 (mm)	270	270	270	270
4.32	Ground clearance, centre of wheelbase	m2 (mm)	330	330	330	330
4.33	Aisle width for pallets 1000 x 1200 crossways (L x W)	Ast (mm)	6,385	6,390	6,960	6,965
4.34	Aisle width for pallets 800 x 1200 lengthways (W x L)	Ast (mm)	6,385	6,390	6,960	6,965
4.35	Turning radius	Wa (mm)	4,080	4,080	4,580	4,580
4.36	Smallest pivot point distance	b13 (mm)	1,515	1,515	1,748	1,748
Performance data						
5.1	Travel speed, unloaded	km/h	35	34.8	33.8	33.6
5.2	Lift speed, loaded/unloaded	m/s	0.44 / 0.51	0.43 / 0.51	0.36 / 0.45	0.35 / 0.45
5.3	Lowering speed, loaded/unloaded	m/s	0.51 / 0.46	0.51 / 0.46	0.43 / 0.39	0.43 / 0.39
5.5	Drawbar pull, loaded	N	90,817	91,405	91,385	91,718
5.7	Gradient performance, loaded/unloaded	%	36.9	33.2	30.0	27.5
5.9	Acceleration time, loaded/unloaded (10m)	sec	-	-	-	-
5.10	Service brake		hydraulic	hydraulic	hydraulic	hydraulic
Engine						
6.1	Engine manufacturer / type		Cummins QSB6.7	Cummins QSB6.7	Cummins QSB6.7	Cummins QSB6.7
6.2	Engine power acc. To ISO 1585	kW	119	119	119	119
6.3	Rated speed	1/min	2,200	2,200	2,200	2,200
6.4	No. of cylinder / cubic capacity	/cm ³	6 / 6,700	6 / 6,700	6 / 6,700	6 / 6,700
6.5	Fuel consumption acc. to VDI cycle	ℓ/h	11.0	11.0	11.5	11.5
Other details						
8.1	Type of drive control		Torque Convert 3/3	Torque Convert 3/3	Torque Convert 3/3	Torque Convert 3/3
8.2	Operating pressure (attachments)	bar	150	150	150	150
8.3	Hydraulic oil flow (attachments)	ℓ/min	295	295	295	295
8.4	Sound level at driver's ear according to DIN 12053	db(A)	76	76	76	76
8.5	Tow coupling, type DIN		-	-	-	-



Notes

A series of horizontal dotted lines for writing notes.

Notes

A series of horizontal dotted lines for writing notes.

Options

- **FORKS: (L x W x T) (mm)**
 - 110D-7E**
75 x 200 x 1,200 / 75 x 200 x 1,500 / 75 x 200 x 1,650 /
75 x 200 x 1,800 / 75 x 200 x 2,100 / 85 x 200 x 2,440
 - 130D-7E**
85 x 200 x 1,200 / 85 x 200 x 1,500 / 85 x 200 x 1,650 /
85 x 200 x 1,800 / 85 x 200 x 2,100 / 90 x 200 x 2,440
 - 140D-7E**
85 x 200 x 1,200 / 90 x 200 x 1,500 / 90 x 200 x 1,650 /
90 x 200 x 1,800 / 90 x 200 x 2,100 / 90 x 200 x 2,440
 - 160D-7E**
90 x 200 x 1,200 / 90 x 200 x 1,500 / 90 x 200 x 1,650 /
95 x 200 x 1,800 / 95 x 200 x 2,100 / 95 x 200 x 2,440
- **MASTS: SIMPLEX MAST / TRIPLEX MAST**
- **FORK EXTENDERS: 1,800 / 2,000 / 2,200 / 2,400 / 2,600**
- **MCV: 4 - SPOOL / 5 - SPOOL**
- **SEAT: HEATED**
- **BEACON LAMP: AMBER / RED / BLUE**
- **FORK POSITIONER**
- **INTEGRATED SIDE SHIFT**
- **INTEGRATED SIDE SHIFT + FORK POSITIONER**
- **EXTRA HYDRAULIC LINE: 3 - SPOOL / 4 - SPOOL / 5 - SPOOL**
- **SOLID TIRES**
- **PNEUMATIC TIRES : LUG / SMOOTH (14/16 ONLY)**
- **WIDE CARRIAGE (2,730 mm)**

Various attachments

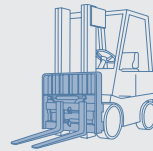

Fork positioner

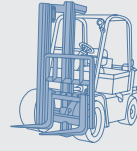

Side shift



110D/130D/140D/160D -7E

Contact your Hyundai dealer for more information. The machine shown may vary according to International standards. All US measurement rounded off to nearest pounds or inches. Materials and specifications are subject to change without notice.

HYUNDAI | FORKLIFT HEAVY INDUSTRIES CO., LTD.

Head Office(Sales Office)
1 JEONHA-DONG, DONG-GU, ULSAN, KOREA Tel (82) (52) 202-7970, 7729, 0971 Fax (82) (52) 202-7979, 7720

U.S. Operation : Hyundai Construction Equipment U.S.A., Inc.
955 ESTES AVENUE, ELK GROVE VILLAGE IL., 60007 Tel (1) 847-437-3333 Fax (1) 847-437-3574

European Operation : Hyundai Heavy Industries Europe N.V.
VOSSENDAAL 11, 2440 GEEL, BELGIUM Tel (32) 14-56-2200 Fax (32) 14-59-3405

India Operation : Hyundai Construction Equipment India Pvt., Ltd
PLOT NO.A-2, CHAKAN INDUSTRIAL AREA, VILL.- KHALUMBRE.
TALUK.- KHED., DIST.- PUNE 410 501, INDIA Tel (91) 21-3530-1700 Fax (91) 21-3530-1712

PLEASE CONTACT

www.hyundai.eu

EN - 2009. 06 Rev 0